

MEDICAL
SINGLE CYLINDER
LB40ME - LB45ME - LB50ME - LB55ME - LB60ME



SINGLE CYLINDER

LB40ME - LB45ME - LB50ME - LB55ME - LB60ME



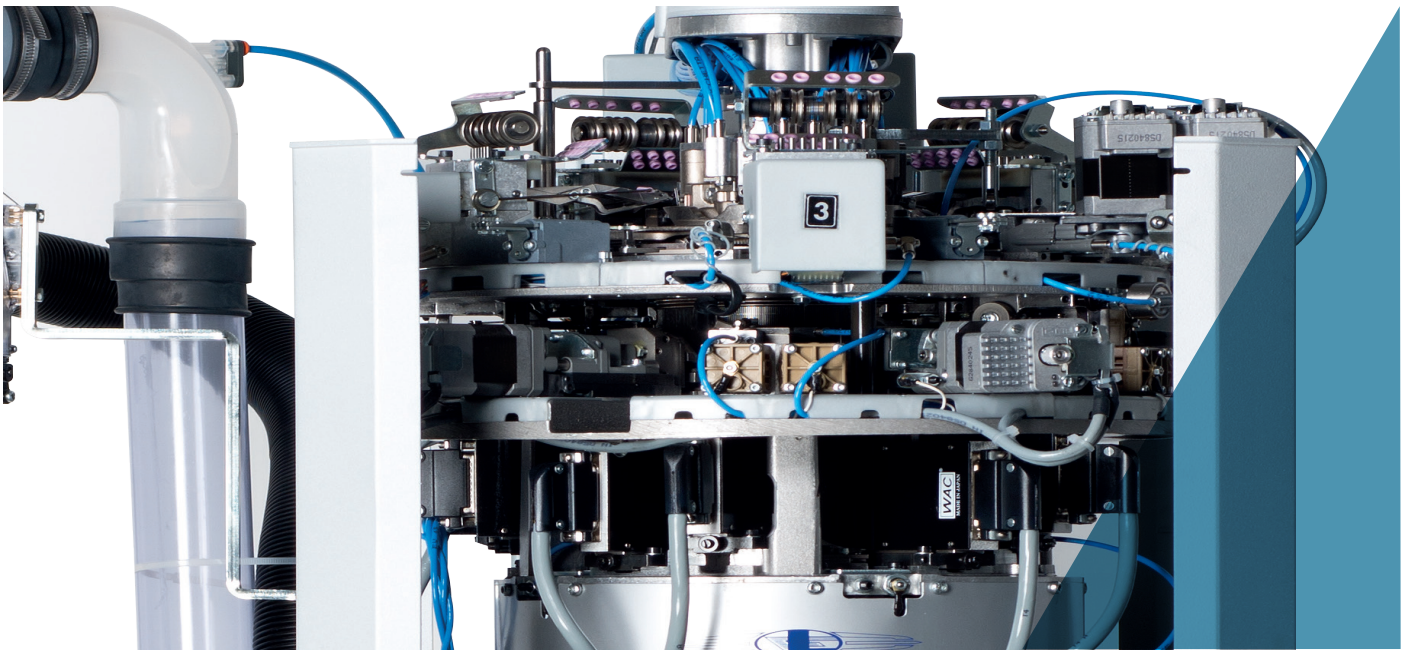

All images in this brochure are indicative and not binding.

SINGLE CYLINDER

LB40ME - LB45ME - LB50ME - LB55ME - LB60ME

Electropneumatic single cylinder 4 feeds machine for the production of class 1,2,3 compression medical socks and medical goods, with reciprocated heel and toe on 1 feed with 2 rising needle pickers and 2 droppers, or pouch type heel and toe. 2 electronic selection units on each feed (one in tucking position and one in clearing position). Motorized stitch cams for enlargements in any area of the garments or on course. Single or double dial jacks. 2 or 4 feeds pattern. reciprocated heel and toe in different sizes and in different positions. Full-electronic programming of the knitting cycle. machine memory for the storing of different items in 8 sizes each. Electronic device to maintain the size at any temperature of the machine.

- 4 feeds single cylinder machine
- 9 pliers suction unit
- 26 yarnfingers
- Motorized sinkers cap, 2 motors
- 5 motorized stitch cams
- 2 electronic selection units on each feed

MACHINE DIMENSIONS



Length cm 60 + yarn creel 145 cm
 Depth cm 60 + yarn creel 145 cm
 Height cm 136 + yarn creel 265 cm

MACHINE WEIGHT



Machine ca. 230 Kg
 Yarn creel ca. 70 Kg

CERTIFICATION



Green
 Label

SINGLE CYLINDER

LB40ME - LB45ME - LB50ME - LB55ME - LB60ME

TECHNICAL DATA

MODEL	CYLINDER DIAMETER	GAUGE	NEEDLE THICKNESS
LB40ME (Needle latch mm. 9,5)	4"	from 14 to 34	0,34 - 0,41 - 0,50 - 0,60 mm
LB45ME (Needle latch mm. 9,5)	4" 1/2	from 17 to 34	0,34 - 0,41 - 0,50 - 0,60 mm
LB50ME (Needle latch mm. 9,5)	5"	from 20 to 32	0,34 - 0,41 - 0,50 - 0,60 mm
LB55ME (Needle latch mm. 9,5)	5" 1/2	from 20 to 32	0,34 - 0,41 - 0,50 - 0,60 mm
LB60ME (Needle latch mm. 9,5)	6"	from 15 to 32	0,34 - 0,41 - 0,50 - 0,60 mm

Above data are indicative and not binding.

STANDARD DEVICES

- Medical creel or 40 or 26 reels yarn creel;
- Sock ejection hood;
- Yarn waste filter;
- Stepper motor controlled suction valve;
- Rotary or fixed antitwist device;
- 5 motorized stitch units;
- Pre-arrangement for 4 medical feeds;
- YOYO pre-arrangement;
- Motorized rising dial;
- Motorized yarn cutter;
- 9 pliers suction unit (plates, hooks and cut-pick);
- 8 yarn sliding sensors;

OPTIONAL DEVICES

- DREAM or DREAM ONE device for stretching socks in ejection
- 2,2 or 3 Kw suction fan
- Ethernet board for connection to Dinema Nautilus data collector system
- Dinema YoYo yarn feeder, 12 max
- Dinema Plus medical or bare elastomer yarn feeders, 8 max
- Yarn sensors, 24 max

ALLOWED YARNS

The machine is designed to be used with the following yarns:

- Nylon
- Filanca
- Elastomers (bare, single or double cover)
- Natural fibers

POSSIBLE KNITTINGS

The standard machine can perform the following knittings

- Plain knit
- 1:1, 3:1, 5:1, 7:1, 1:3 fixed mesh, micromech and diagonal mesh
- Several laid-in pattern (piquet effect), tucking, bikini pattern, cut boss etc.
- Reciprocated motion option in variable size and in any area
- Supp-hose on 2 or 4 feeds
- Plating on 4 feeds

SINGLE CYLINDER

LB40ME - LB45ME - LB50ME - LB55ME - LB60ME

NUMBER OF COLORS

Number of colors	<ul style="list-style-type: none"> - Working feeds 1-2-3-4: one color each course - Working feeds 1-3 or 2-4: 2 colors each course - Working feed 4: 3 colors each course
------------------	--

PERFORMANCES

	4" Ø CYLINDER (LB40ME) 4" 1/2 Ø CYLINDER (LB45ME) 5" Ø CYLINDER (LB50ME) 5" 1/2 Ø CYLINDER (LB55ME) 6" Ø CYLINDER (LB60ME)
GAUGE	from 14 to 32
MAXIMUM SPEED	500 rpm (LB40), 450 rpm (LB45), 400 rpm (LB50), 350 rpm (LB55), 300 rpm (LB60)

Above data are indicative and not binding.

DISCLAIMER:

Speed may need to be adjusted according to the inclination of the stitch cams, to the mechanical parts in use and to the yarn.
N.B. All data in the brochure are for information only and subject to change without any prior notice from Lonati SpA.

	CYLINDER Ø 4" (LB40ME), 4" 1/2 (LB45ME), 5" (LB50ME), 5" 1/2 (LB55ME), 6" (LB60ME)
GAUGE	from 14 to 32
MAXIMUM SPEED	500 rpm (LB40), 450 rpm (LB45), 400 rpm (LB50), 350 rpm (LB55), 300 rpm (LB60)

ALLOWED PERFORMANCES

CHART OF MAXIMUM ALLOWED SPEED IN PLAIN KNIT IN RELATION TO THE INCLINATION TO THE STITCH CAMS	
Stitch cam inclination	Maximum allowed speed in plain knit
58° - LB40ME	500
58° - LB45ME	450
58° - LB50ME	400
58° - LB55ME	350
58° - LB60ME	300

NUMBER OF POSSIBLE COLORS ON EACH COURSE ACCORDING TO THE NUMBER OF WORKING FEEDS	
Working feeds	Number of colors
1° - 2° - 3° - 4°	1 x each course
2° - 4°	2 x each course
4°	3 x each course

Above data are indicative and not binding.

DISCLAIMER:

All data related to maximum allowed mechanical speed may require to be reduced (to be adjusted according to functional tests on the machine) when using specific particular yarns and/or knitting features.

SINGLE CYLINDER

LB40ME - LB45ME - LB50ME - LB55ME - LB60ME

CYLINDERS				
MACHINE	NEEDLES NUMBER	NEEDLE THICKNESS	MACHINE GAUGE	NEEDLE TYPE
LB40ME (4")	176	mm. 0,50 GG 54	14	G045-G040
	192	mm. 0,60 GG 48	15	G0311-G0312
	200	mm. 0,60 GG 48	16	G0311-G0312
	208	mm. 0,50 GG 54	16-17	G045-G040
	240	mm. 0,60 GG 48	19	G0311-G0312
	240	mm. 0,50 GG 54	19	G045-G040
	256	mm. 0,50 GG 54	20	G045-G040
	288	mm. 0,50 GG 54	23	G045-G040
	288	mm. 0,41 GG 70	23	G07401-G07402
	304	mm. 0,41 GG 70	24	G07401-G07402
	320	mm. 0,41 GG 70	26	G07401-G07402
	320	mm. 0,34 GG 75	26	G07711-G07712
	328	mm. 0,41 GG 70	26	G07401-G07402
	336	mm. 0,41 GG 70	26	G07401-G07402
	336	mm 0,34 GG 75	27	G07711-G07712
	341	mm. 0,41 GG 70	28	G07401-G07402
	352	mm. 0,41 GG 70	28	G07401-G07402
	352	mm.0,34 GG 75	28	G07711-G07712
	358	mm. 0,41 GG 70	28	G07401-G07402
	368	mm. 0,41 GG 70	30	G07401-G07402
	368	mm. 0,34 GG 75	30	G07711-G07712
	375	mm. 0,41 GG 70	30	G07401-G07402
	384	mm. 0,34 GG 75	30	G07711-G07712
	400	mm. 0,34 GG 75	32	G07711-G07712
401	mm. 0,34 GG 75	32	G07711-G07712	
402	mm. 0,34 GG75	32	G07711-G07712	
432	mm. 0,34 GG 75	34	G07711-G07712	

CYLINDERS				
MACHINE	NEEDLES NUMBER	NEEDLE THICKNESS	MACHINE GAUGE	NEEDLE TYPE
LB45ME (4"½)	240	mm. 0,60 GG 48	17	G0311-G0312
	254	mm. 0,60 GG 48	18	G0311-G0312
	270	mm. 0,60 GG 48	19	G0311-G0312
	282	mm. 0,60 GG 48	20	G0311-G0312
	288	mm. 0,60 GG 48	20	G0311-G0312
	320	mm. 0,50 GG 54	22	G045-G040
	340	mm. 0,50 GG 54	24	G045-G040
	340	mm. 0,41 GG 70	24	G07401-G07402
	352	mm. 0,50 GG 54	25	G045-G040
	352	mm. 0,41 GG 70	25	G07401-G07402
	368	mm. 0,41 GG 70	26	G07401-G07402
	369	mm. 0,41 GG 70	26	G07401-G07402
	372	mm. 0,41 GG 70	26	G07401-G07402
	376	mm. 0,41 GG 70	26	G07401-G07402
	384	mm. 0,41 GG 70	27	G07401-G07402
	396	mm. 0,41 GG 70	28	G07401-G07402
	400	mm. 0,41 GG 70	28	G07401-G07402
	400	mm. 0,34 GG 75	28	G07711-G07712
	420	mm. 0,41 GG 70	30	G07401-G07402
	425	mm. 0,41 GG 70	30	G07401-G07402
	440	mm. 0,34 GG 75	31-32	G07711-G07712
	448	mm. 0,34 GG 75	32	G07711-G07712
	451	mm. 0,34 GG 75	32	G07711-G07712
	480	mm. 0,34 GG 75	34	G07711-G07712

SINGLE CYLINDER

LB40ME - LB45ME - LB50ME - LB55ME - LB60ME



CYLINDERS				
MACHINE	NEEDLES NUMBER	NEEDLE THICKNESS	MACHINE GAUGE	NEEDLE TYPE
LB50ME (5")	312	mm. 0,60 GG 48	20	G0311-G0312
	313	mm. 0,60 GG 48	20	G0311-G0312
	320	mm. 0,60 GG 48	20	G0311-G0312
	336	mm. 0,50 GG 54	22	G0045-G040
	376	mm. 0,41 GG 70	24	G07401-G07402
	376	mm. 0,50 GG 54	24	G045-G040
	384	mm. 0,50 GG 54	24	G045-G040
	391	mm. 0,50 GG 54	26	G045-G040
	399	mm. 0,41 GG 70	25-26	G07401-G07402
	400	mm. 0,50 GG 54	25-26	G045-G040
	408	mm. 0,41 GG 70	26	G07401-G07402
	420	mm. 0,41 GG 70	27	G07401-G07402
	432	mm. 0,41 GG 70	28	G07401-G07402
	436	mm. 0,41 GG 70	27	G07401-G07402
	440	mm. 0,41 GG 70	28	G07401-G07402
	444	mm. 0,41 GG 70	28	G07401-G07402
	472	mm. 0,41 GG 70	30	G07401-G07402
	496	mm. 0,34 GG 75	32	G07711-G07712
501	mm. 0,34 GG 75	32	G07711-G07712	

CYLINDERS				
MACHINE	NEEDLES NUMBER	NEEDLE THICKNESS	MACHINE GAUGE	NEEDLE TYPE
LB50ME (5" ½)	352	mm. 0,60 GG 48	20	G0311-G0312
	420	mm. 0,50 GG 54	24	G045-G040
	480	mm. 0,41 GG 70	28	G07401-G07402
	484	mm. 0,41 GG 70	28	G07401-G07402
	560	mm. 0,34 GG 75	32	G07711-G07712

CYLINDERS				
MACHINE	NEEDLES NUMBER	NEEDLE THICKNESS	MACHINE GAUGE	NEEDLE TYPE
LB50ME (6")	288	mm. 0,70 GG 36	16	
	288	mm. 0,60 GG 48	16	G0311-G0312
	289	mm. 0,60 GG 48	16	G0311-G0312
	366	mm. 0,60 GG 48	20	G0311-G0312
	368	mm. 0,60 GG 48	20	G0311-G0312
	400	mm. 0,60 GG 48	21	G0311-G0312
	452	mm. 0,50 GG 54	24	G045-G040
	528	mm. 0,41 GG 70	28	G07401-G07402
	600	mm. 0,34 GG 75	32	G07711-G07712

Above data are indicative and not binding.

SINGLE CYLINDER

LB40ME - LB45ME - LB50ME - LB55ME - LB60ME

NOISE LEVEL

Machine average noise level, suction included LeqA = 74dBA

LUBRICANTS

Average consumption for 500/600 dozens: 1000 gr. - Lonati recommends: Fuchs Trax 14C - Kluber Tex Sintheso M32 - Esso Eil 0287

GREASE

For seals, bearings etc. Lonati recommends: Damping grease Nyogel 774F

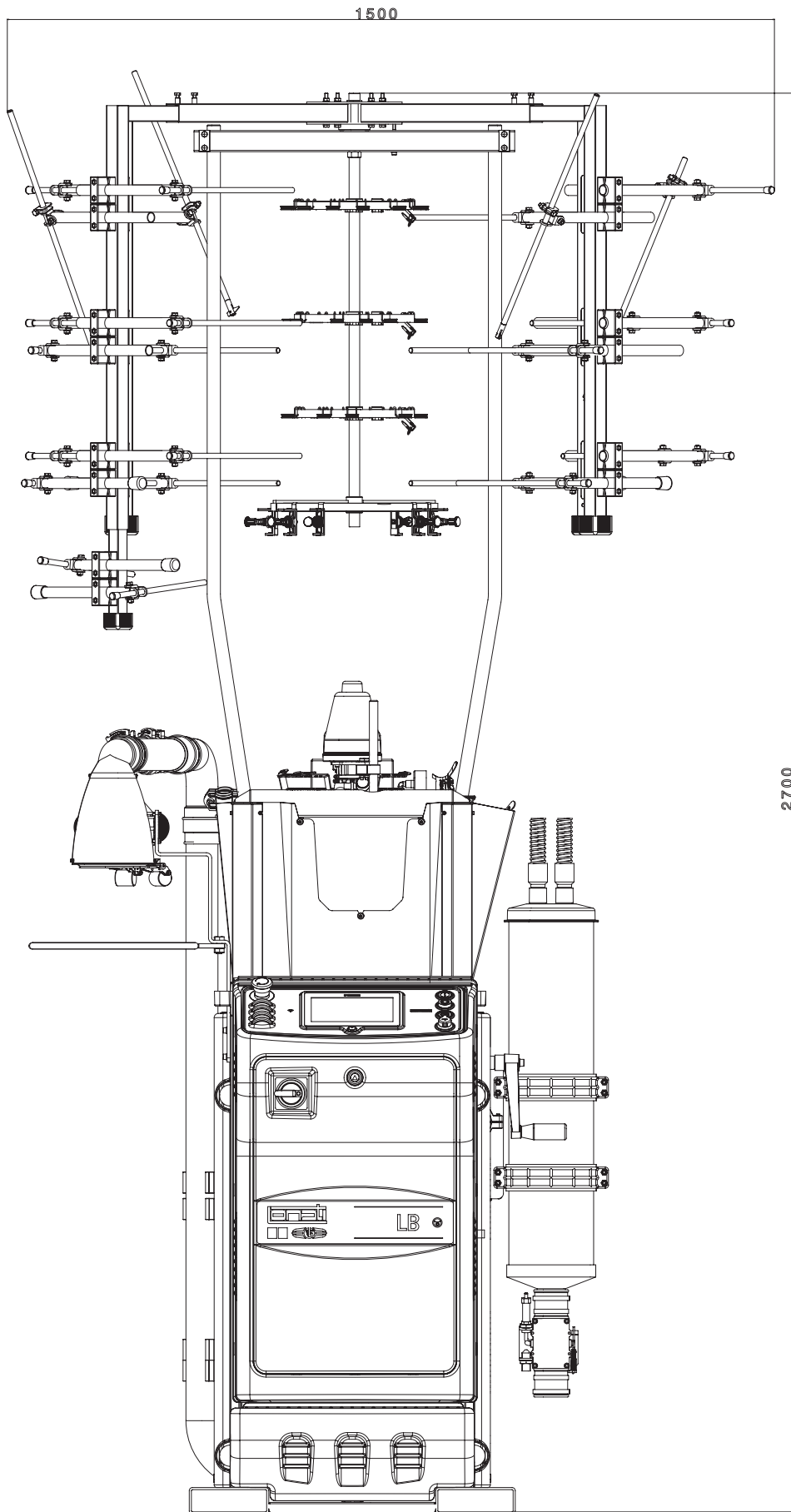

FRONT VIEW

Machine dimensions with 26 reels yarn creel

NOTE:

The picture may show fittings and equipment that are supplied on demand and not.

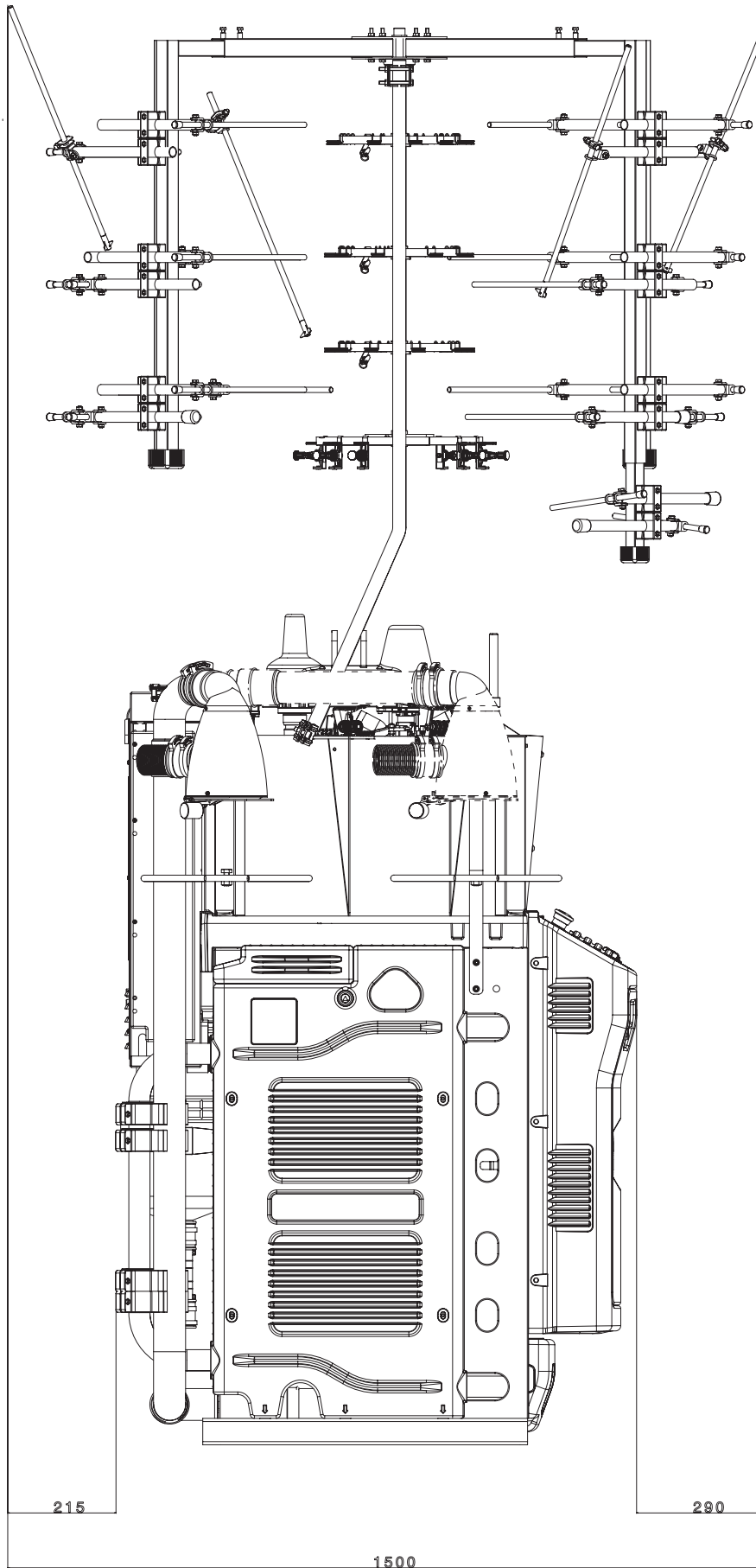

SIDE VIEW

Machine dimensions with 26 reels yarn creel

NOTE:

The picture may show fittings and equipment that are supplied on demand and not.

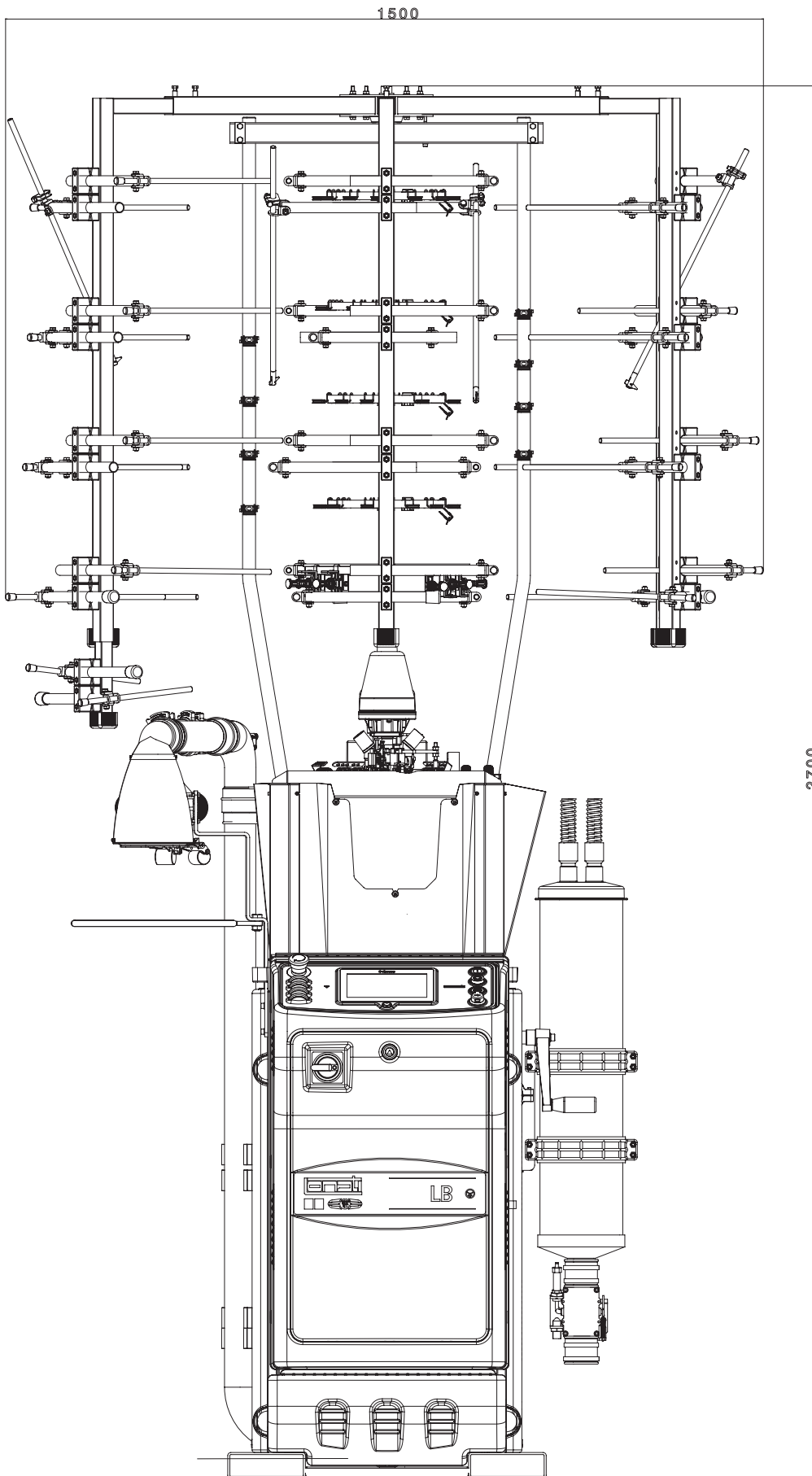

FRONT VIEW

Machine dimensions with 40 reels yarn creel

NOTE:

The picture may show fittings and equipment that are supplied on demand and not.

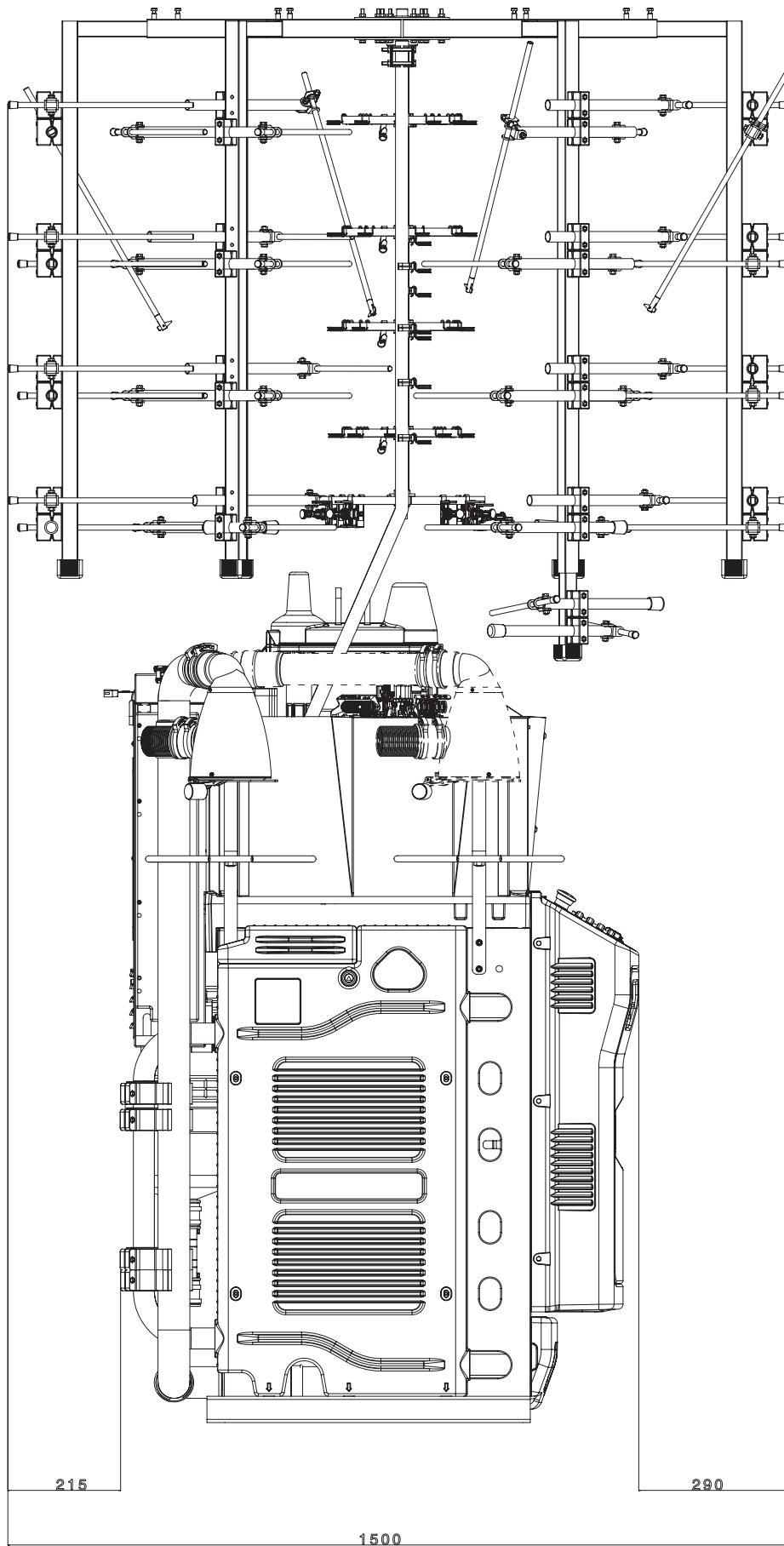

SIDE VIEW

Machine dimensions with 40 reels yarn creel

NOTE:

The picture may show fittings and equipment that are supplied on demand and not.

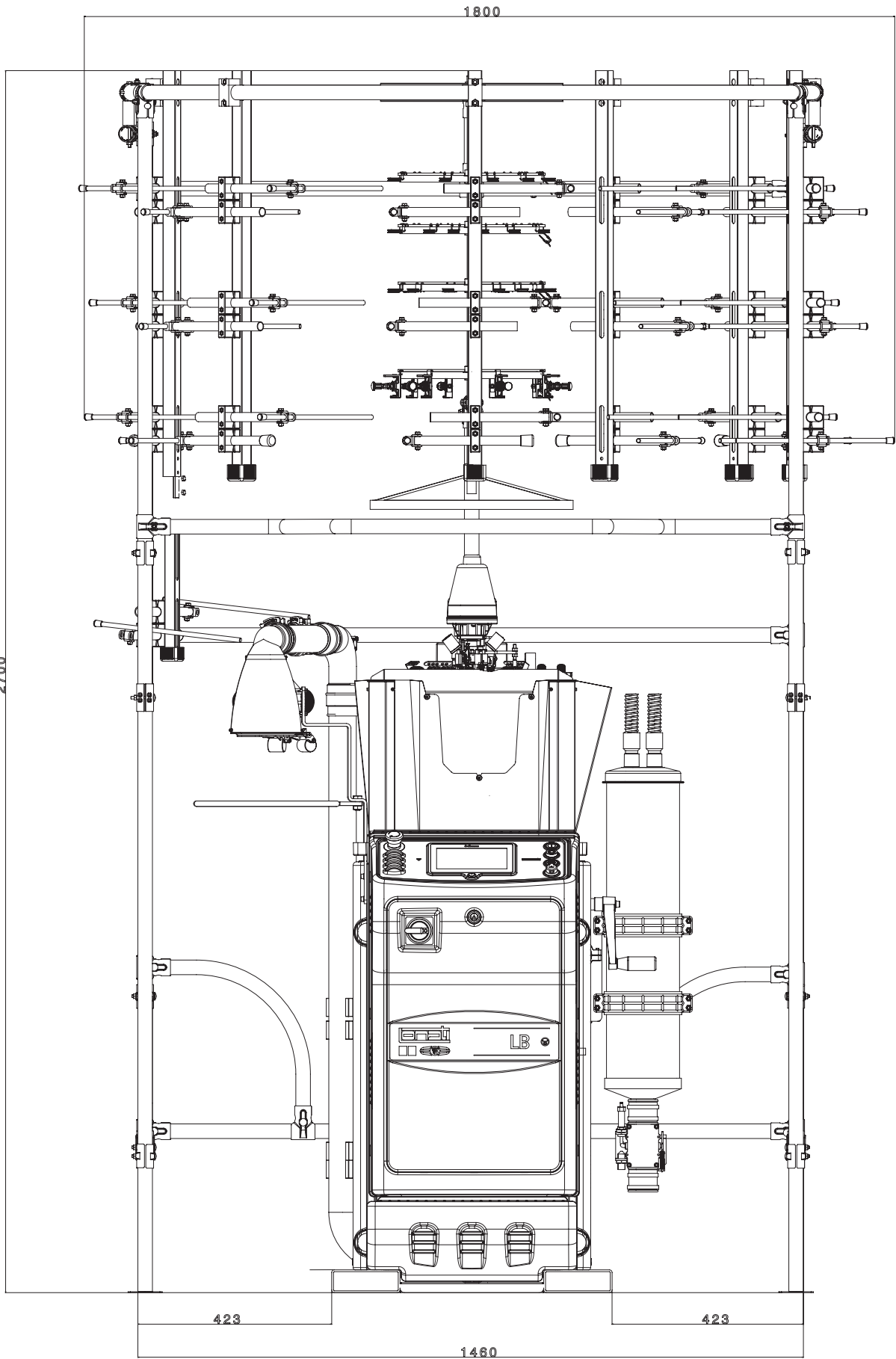

FRONT VIEW

Machine dimensions with medical yarn creel

NOTE:

The picture may show fittings and equipment that are supplied on demand and not.

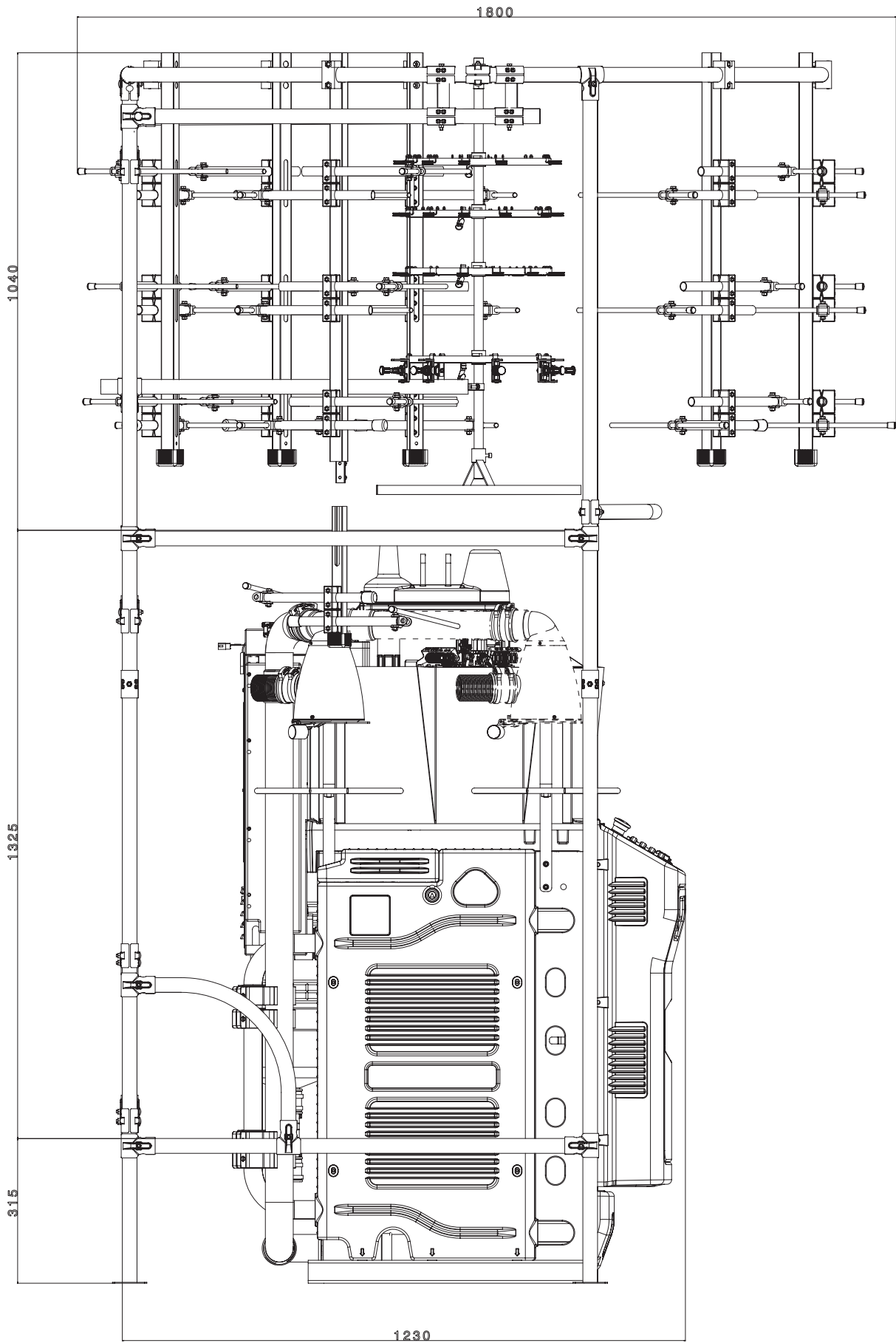

SIDE VIEW

Machine dimensions with medical yarn creel

NOTE:

The picture may show fittings and equipment that are supplied on demand and not.





LONATI SPA

Via Francesco Lonati, 3 | 25124 Brescia (Italy)
Tel. +39 03023901 | Fax +39 030 2310024
C.F.: 01469680175 | P.iva: 02096730961
info@lonati.com - www.lonati.com